

# Illuminating innovation

*Tailored PCT resins for LED packaging applications*

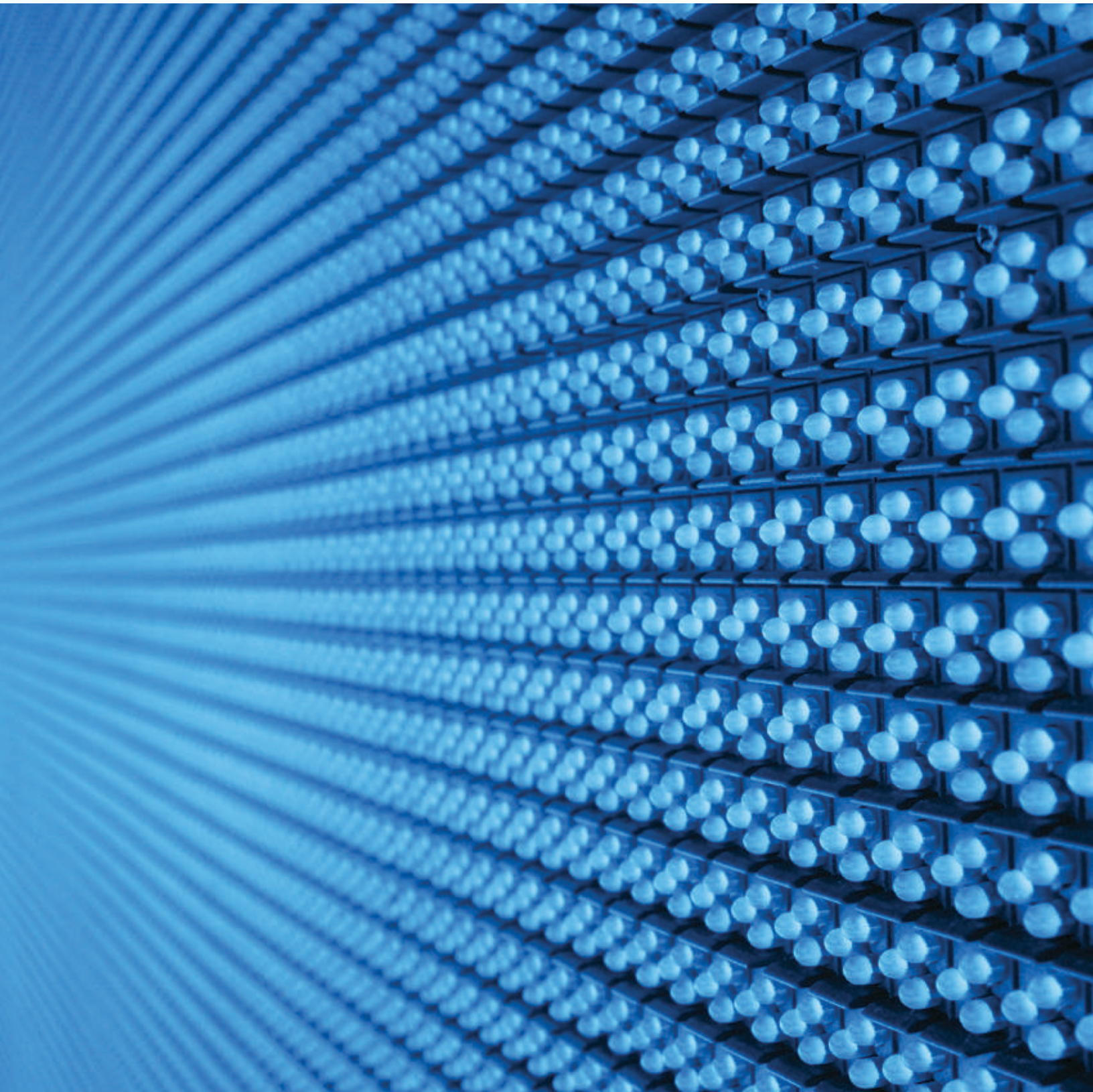

# Leading the way in LED packaging

The emergence of light-emitting diode (LED) technology has created untold design opportunities for a variety of markets—particularly electronics, automotive, architecture, home appliances, and housewares.

It's also created challenges. For example, today's manufacturers are being asked to develop increasingly smaller packaged LEDs with lifetimes in excess of 20 years. As such, innovative LED systems demand a polymer used to build packaged LEDs that is easy to process, heat resistant, color stable, durable, and is highly reflective. For the LED market, polycyclohexylenedimethylene terephthalate (PCT) is quickly becoming the polymer of choice.

And Eastman remains the manufacturer of choice for PCT resins.

## The material choice that reflects well on you

In state-of-the-art display backlighting and general LED lighting, good long-term reflectivity is essential for LED packaging compounds.

Compared to polyphthalamide (PPA), Eastman PCT resins demonstrate superior color stability over time, ensuring optimal reflectivity for the life of the LED device.

## Lot to lot consistency—Made in the U.S.A.

Backlighting for TV monitor devices, entertainment systems, and other applications requires that the LED reflectors be molded into small, thin-walled shapes using multicavity molds. This requires the mechanical strength to assure there is no breakage under load during molding and processing.

Short-term heat resistance is necessary to maintain reflectivity during encapsulating and soldering. While long-term heat and light resistance helps maintain reflectivity during end use.

With Eastman's trusted and proven manufacturing, OEMs are ensured our PCT resins demonstrate consistent high quality every time—and for the long haul.

Eastman PCT resins are ideal for LED packaging applications. Unlike high-melting polyamides, which yellow from exposure to heat and light, these engineering-grade resins enhance LED packaging through:

- High reflectivity
- Superior durability
- Long-term heat resistance
- Low moisture absorption
- Dimensional stability during reflow and lead-free soldering processes
- Excellent metal adhesion
- High-gloss out-of-mold surfaces
- Lot-to-lot consistency
- Reliability of supply
- Eastman support and innovation

Color stability comparison of aged PPA and Eastman PCT compounds at 170°C

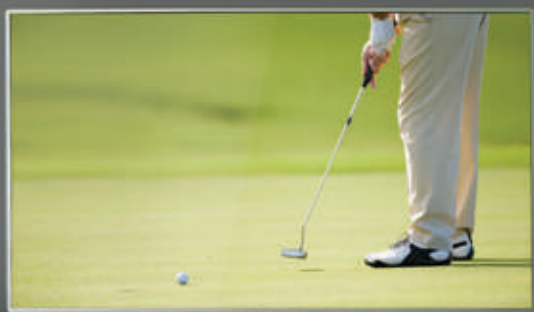
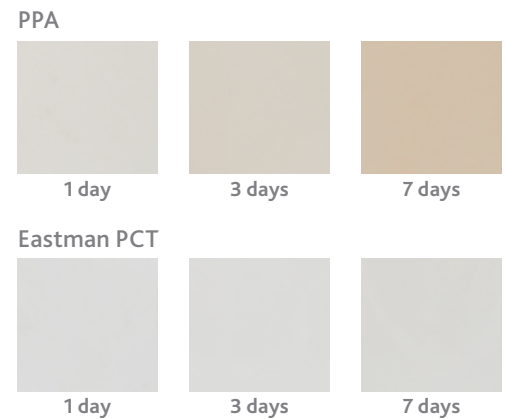

## Tailored to fit your needs

At Eastman, we leverage proprietary technology and extraordinary insight to manufacture the world's broadest portfolio of thermoplastic polyester materials.

By tailoring polymers to meet specific requirements, we can create solutions that exhibit just the right thermal, mechanical, and rheological characteristics you need. The results are specialty plastics that offer superior toughness, clarity, color, flexibility, flow, chemical resistance, and more.

That's also why you'll find us working with some of the world's most innovative and pioneering brands. The true brilliance of Eastman's polymer design doesn't lie in where you'll find us today—it's where you'll find us tomorrow.

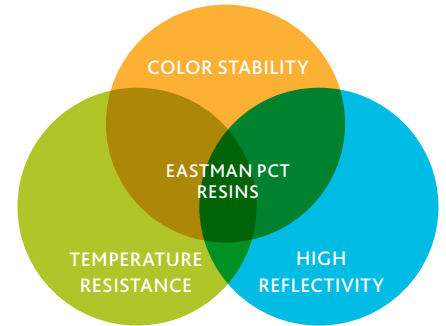

### Eastman PCT characteristics

Product		Amorphous		Crystallized*	
		Eastman PCT 36294	Eastman PCT 36296	Eastman PCT 36294	Eastman PCT 36296
IV		0.62	0.72	0.62	0.72
Flexural properties (ASTM D790) @ 23°C	Units				
Yield stress	MPa	66.6	65.0	64.0	90.0
Yield strain	%	6.3	6.2	3.0	5.0
Break stress	MPa	66.0	64.4	71.0	90.0
Break strain	%	7.0	7.0	3.0	5.0
Flexural modulus	MPa	1712	1635	2112	2103
IZOD impact (ASTM D4812) @ 23°C	Units				
% Break	%	0	0	90	10
Tensile (ASTM 638) @ 23°C	Units				
Tensile yield	MPa	42.9	42.4	30.6	47.9
Tensile @ break	MPa	50.0	51.0	30.5	47.9
Elongation	%	5.0	4.6	1.8	3.0
Elongation @ break	%	244	236	2	3
Tensile modulus	MPa	1529	1519	2046	1922
DSC analysis	Units				
T <sub>g</sub> 2nd heat	°C	95	95	95	95
T <sub>m</sub> 2nd heat	°C	288	288	288	288

\*Molded parts were crystallized in an oven for 20 minutes at 170°C.

Typical packaged LED construction

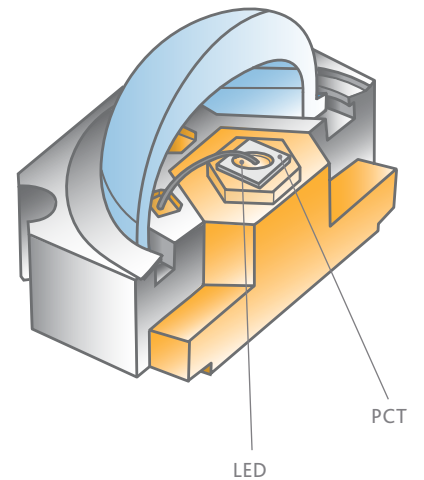

## About Eastman

Eastman is a global specialty chemical company that produces a broad range of advanced materials, additives and functional products, specialty chemicals, and fibers. Today, the world depends on our insights to create the materials found in thousands of household and industrial products. To do this, we work with customers worldwide to innovate, discover, and implement practical solutions that meet persistent and emerging needs in ever-changing global markets.

With manufacturing sites across North America, Latin America, Europe, and Asia, we are putting our chemistry to work, creating "The results of insight™."

**For more information, contact your Eastman representative.**

**EASTMAN**

The results of insight™

**Eastman Chemical Company  
Corporate Headquarters**

P.O. Box 431

Kingsport, TN 37662-5280 U.S.A.

U.S.A. and Canada, 800-EASTMAN (800-327-8626)

Other Locations, +(1) 423-229-2000

[www.eastman.com/locations](http://www.eastman.com/locations)

Although the information and recommendations set forth herein are presented in good faith, Eastman Chemical Company and its subsidiaries make no representations or warranties as to the completeness or accuracy thereof. You must make your own determination of its suitability and completeness for your own use, for the protection of the environment, and for the health and safety of your employees and purchasers of your products. Nothing contained herein is to be construed as a recommendation to use any product, process, equipment, or formulation in conflict with any patent, and we make no representations or warranties, express or implied, that the use thereof will not infringe any patent. NO REPRESENTATIONS OR WARRANTIES, EITHER EXPRESS OR IMPLIED, OF MERCHANTABILITY, FITNESS FOR A PARTICULAR PURPOSE, OR OF ANY OTHER NATURE ARE MADE HEREUNDER WITH RESPECT TO INFORMATION OR THE PRODUCT TO WHICH INFORMATION REFERS AND NOTHING HEREIN WAIVES ANY OF THE SELLER'S CONDITIONS OF SALE.

Safety Data Sheets providing safety precautions that should be observed when handling and storing our products are available online or by request. You should obtain and review available material safety information before handling our products. If any materials mentioned are not our products, appropriate industrial hygiene and other safety precautions recommended by their manufacturers should be observed.

© 2017 Eastman Chemical Company. Eastman brands referenced herein are trademarks of Eastman Chemical Company or one of its subsidiaries or are being used under license. The ® symbol denotes registered trademark status in the U.S.; marks may also be registered internationally. Non-Eastman brands referenced herein are trademarks of their respective owners.